



EXAMINATIONS COUNCIL OF LESOTHO
Lesotho General Certificate of Secondary Education

DESIGN AND TECHNOLOGY

Paper 1

0189/01

October/November 2018

2 hours 30 minutes

Additional Materials: Answer Paper
 Sketching equipment

READ THESE INSTRUCTIONS FIRST

Write your Centre number, candidate number and name on all the work you hand in.
Write in dark blue or black pen.
You may use an HB pencil for any diagrams, graphs and rough working.
Do not use staples, paper clips, glue or correction fluid.

Part A

Answer **all** questions.
You are advised to spend no more than 45 minutes on this part.

Part B

Answer four questions, **two** from Section 1 and **two** from Section 2.
You are advised to spend no more than 1 hour 45 minutes on Part B.

Use sketches where appropriate to clarify your answers.
At the end of the examinations, fasten all your work securely together.
The number of marks is given in brackets [] at the end of each question or part question.

084

A001



This document consists of **8** printed pages.



Part A

You are advised to spend no more than 45 minutes on this part.

Answer **all** questions.

- 1 Name any type of adhesive that can be used to glue metal and wood together. [1]
- 2 State the working names of a particle board and fibreboard and for each, give an example of their use. [4]
- 3 **Fig. 1** shows a woodworking tool.

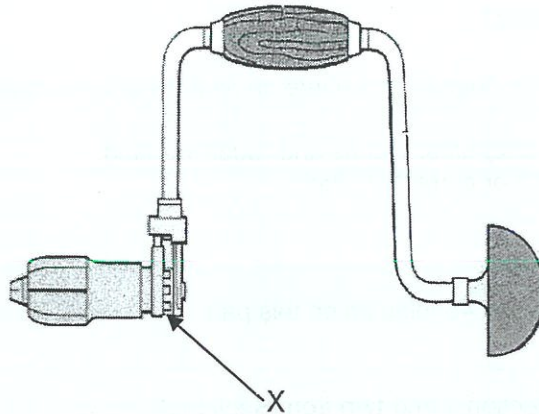

Fig. 1

- (a) Name the tool. [1]
 - (b) State **two** uses of the tool. [2]
 - (c) State the function of the part labelled X. [1]
- 4 Explain why the striking faces of a carpenter's mallet are tapered. [1]
 - 5 Explain the difference between the "points"/teeth of a rip and cross-cut saw. [2]
 - 6 Sketch folding bars being used. [4]
 - 7 Name a suitable metal for making the handle of hacksaw and state **two** reasons for the choice of material. [3]
 - 8 State **three** natural timber defects. [3]

- 9 State **three** uses of unplasticised P.V.C. [3]
- 10 State **three** properties of acrylic that make it suitable for lenses of car lights. [3]



Part B

You are advised to spend no more than 1 hour 45 minutes on this part of the examination.

Answer **four** questions, **two** from Section 1 and **two** from Section 2.

All questions carry equal marks.

Section 1 – Tools and Materials

Answer **two** questions.

11 Fig. 2 shows fixing devices used to join materials.

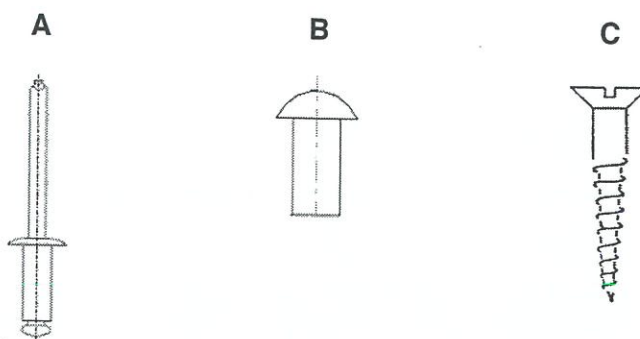

Fig. 2

- (a) Name each of the fixing devices and for each, give a use. [6]
- (b) For each fixing shown in Fig. 2, name the main tool needed to lock or drive fixings. [3]
- (c) Fixing **A** and **B** have to be made from a malleable material.
- (i) Explain the term malleable. [2]
- (ii) State any **two** materials that could be used to make both fixings **A** and **B**. [2]
- (d) Name the tool that can be used to make the hole to receive the head of fixing **C**. [1]
- (e) Explain how fixing **A** can be removed from a joint. [1]
- (f) State any safety precaution in relation to each of the fixings shown. [3]

12 Some workshop processes pose a danger to the worker.

- (a) Copy and complete the table below.
The first row has been completed for you.

Process	Possible danger	Protective clothing/ equipment
welding	too much light intensity will damage the eyes	welding helmet
laying GRP		
turning a piece of hardwood on a lathe		
forging a piece of mild steel		

[6]

- (b) Give **two** safety precautions in relation to:

- (i) Tools with cutting edges;
- (ii) Behaviour in the workshop;
- (iii) Sanding soft wood.

[6]

- (c) Use notes and sketches to show how a mortise gauge is set.

[4]

- (d) Name the tool shown in **Fig. 3** and state its use.

[2]

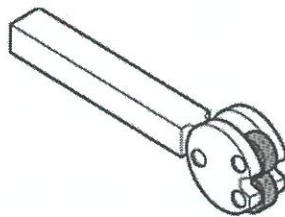

Fig. 3

13 Fig. 4 shows different metal forms.

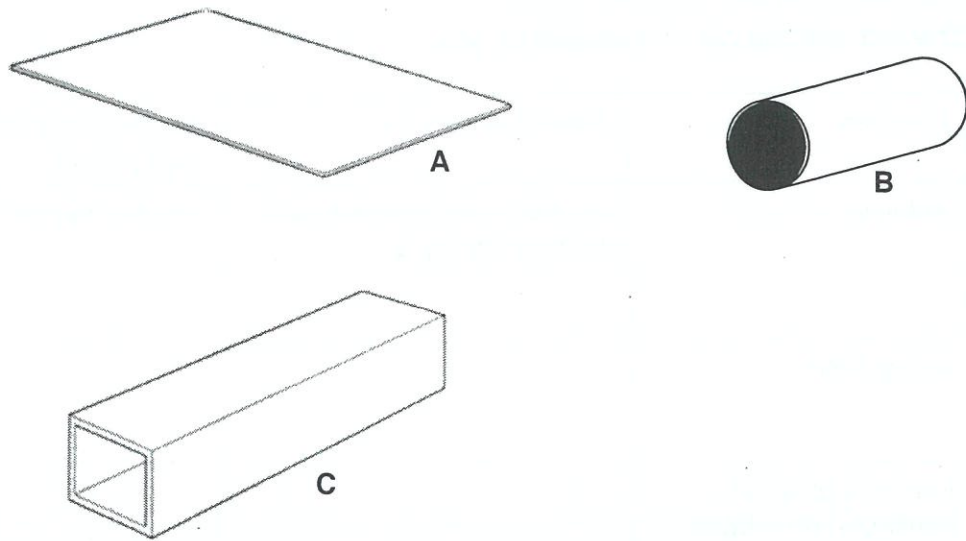

Fig. 4

- (a) (i) Name each form of material. [3]
 (ii) Identify a situation in which each form could be used. [3]
- (b) State **three** factors which should be considered when selecting materials for use. [3]
- (c) (i) State the danger that could be created when handling the edge of the material shown in **A**. [1]
 (ii) Use notes and sketches to show how changes could be made to the edge of the material in **A** to prevent danger. [3]
- (d) Mention **two** methods of applying a finish on material **C**. [2]
- (e) Explain how material **A** could be bent to a 90° angle if it was made from acrylic. [3]



Section 2 – Processes

Answer **two** questions.

14 Fig. 5 shows a table tennis bat.

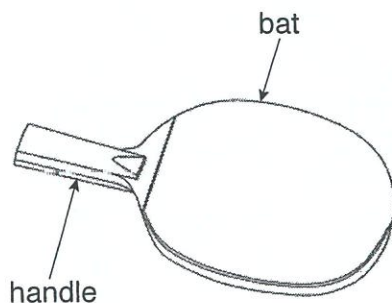

Fig. 5

- (a) Name a suitable wood for the:
- | | |
|--------------|-----|
| (i) Bat; | [1] |
| (ii) Handle. | [1] |
- (b) Use notes and sketches to show how to:
- | | |
|-----------------------|-----|
| (i) Mark-out the bat; | [4] |
| (ii) Cut-out the bat. | [6] |
- (c) Use notes and sketches to show how the bat will be joined to the handle. [4]
- (d) Give **two** methods which could be used to improve the grip of the handle when using the bat. [2]



15 Fig. 6 shows a hand held thread winder suitable for kite flying.

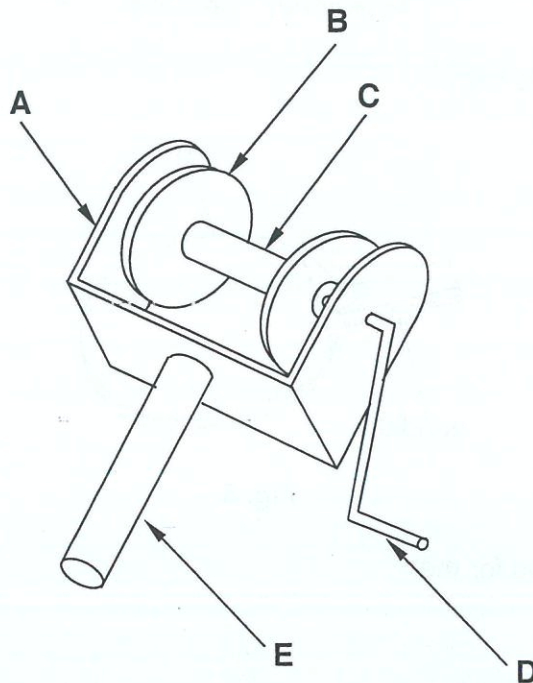

Fig. 6

- (a) State the material that could be used to make each of the parts A, B, C, D, and E. [5]
- (b) Explain with the aid of notes and sketches how part E could be joined to part A. [5]
- (c) Use notes and sketches to show how parts A and B could be produced. [8]

16 Below is a list of workshop processes.

Choose any **three** of the processes and use notes and sketches to show how each is carried out.

- (a) Injection moulding [6]
- (b) Faceplate turning [6]
- (c) Case hardening [6]
- (d) Die Casting in school workshop [6]

